

## 7. IT'S NOT ALL BUBBLE BATHS



**T**he bathroom is what I like to call a project-rich environment. Though it's usually the smallest room in the house, it provides a seemingly endless list of repair opportunities and home improvement project possibilities. Bathroom projects can be divided into at least two categories: water-related and non-water-related.

### 1. WATER-RELATED PROJECTS:

- ✓ Turning off the main water supply line
- ✓ Fixing a leaky faucet
- ✓ Basic toilet repair
- ✓ The sink pop-up thingy
- ✓ Installing a new shower head
- ✓ Sink aerators
- ✓ Replacing caulk
- ✓ Repairing grout

### 2. NON-WATER-RELATED PROJECTS:

- ✓ Replacing a medicine cabinet
- ✓ Installing safety grab bars
- ✓ Installing toilet paper and towel bars that stay on the wall
- ✓ Updating vanity or cabinet hardware
- ✓ Painting an old, ugly vanity

The projects on the non-water-related list are often found on a woman's "Wouldn't it be nice" list, while the water-related projects are always on the "I know I have to" home maintenance list.



**IT HAPPENED TO ME ONCE:** I continue to be amazed by how some clients I have visited over the years can remain in complete denial about the extent of the damage their seemingly small, innocuous water problems are causing. I'll give you two examples:

**STORY #1:** Several years ago, I was hired by a new client to repair some drywall adjacent to a tub surround that had been damaged by water. While I was fixing the drywall, I noticed that there was water around the base of the toilet. More water appeared each time the toilet was flushed. I finished the first round of wall repair and informed my client about the problem that I noticed with her toilet. She said that there had been water on the floor for a long time, but she thought she was just splashing water from the vanity onto the floor. I strongly suggested she call a plumber, and departed. I returned a few weeks later to finish the wall repair, and I checked to see if the toilet had been repaired. It hadn't. She was completely ignoring the water issue. If she had called a plumber when she first noticed the problem, it would have been a simple matter of replacing the wax ring under the toilet. By the time she got around to getting it fixed, however, it was going to require repairs to the subfloor as well as new linoleum.

**STORY #2:** About a year ago, I was hired to do regular handywoman work at a retirement home for nuns. I stop by about one day every couple of months and take care of whatever has shown up on their "to-do" list. The sister in charge had told me that one of the bathtubs surrounds needed new caulk. When I arrived, I discovered that a long piece of gray duct tape had been placed over the joint where the tiled tub surround met the tub. When I started to remove the duct tape, the wall tiles came off with it. I removed about twenty wall tiles and discovered that part of the wall behind the tile was completely destroyed by long-term exposure to water and needed to be rebuilt.

I could fill this book with similar stories, but instead I'll simply restate my point: In both of these situations and with ninety-five percent of all others, if the repair had taken place at the first suspicion of a problem it would have been a minor one. Unless you suffer a catastrophic flood, it takes a long time for most water damage to occur. If something gets wet just once, it will dry out and will probably be fine; if it gets wet and remains wet for months or years, however, the extent of the damage is always major and will usually involve mold, or even insects. I have found termites or carpenter ants living happily in someone's rotted wood on more than one occasion when I was dealing with water damage. Don't let that happen to you.

After reading this book, I hope that you will have the knowledge and information you need to nip some water-related problems in the bud on your own. If you don't feel comfortable taking on any kind of water-related problem, make sure you call a plumber at the first suspicion of a problem. Whatever you pay the plumber will be much less than you would pay to fix the damage caused by the problem years down the road if it goes unchecked.

## Where Water Comes From and Why It's Important to Know

Whenever I speak to a group of women, I always ask if they know where the main water shut-off valve is located in their home. Usually, less than half the women raise their hands. So I give them a homework assignment: Go home and locate your main water supply shut-off valve.

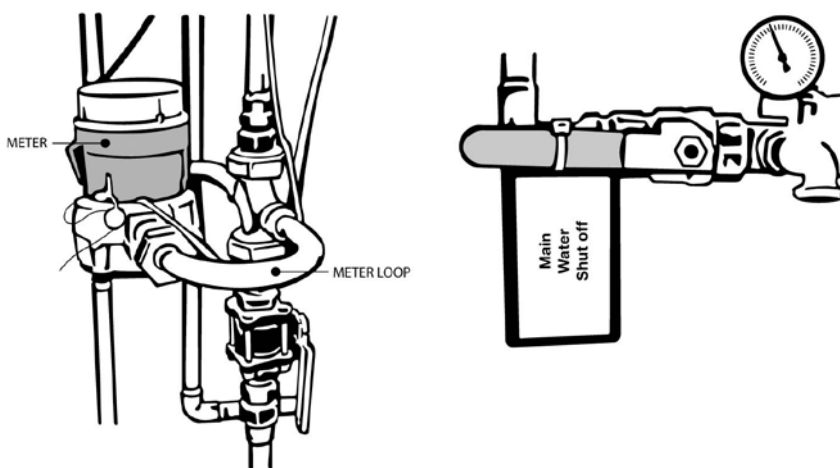

Here's why: If you ever walk through your doors and discover that the hose burst on your washing machine, or that your toilet is overflowing, the fastest way to stop it is to shut off the water supply to the entire house. The location of the shut off valve will vary depending on what region of the country you live in, and whether you have a well or your water is supplied by your city or town.



**IMPORTANT NOTE:** The shut-off valve is usually located inside the house, on the side of the house closest to the street (if you have town water), or close to the well (if you have a private water supply). It will often be in your "mechanical" room, which can contain your hot water heater, furnace, water treatment system, etc. Take the time to find it so you'll know where it is if you ever need it.

There are other shut off valves located throughout your home, usually (but not always) wherever there are faucets or toilets. Modern plumbing code requires shut-off valves for each faucet, but if you have some ancient plumbing you may be missing a valve or two. If you look under your kitchen sink and bathroom vanity, you should see a shut-off valve for both the hot and cold supply lines, which provide water to the faucet.

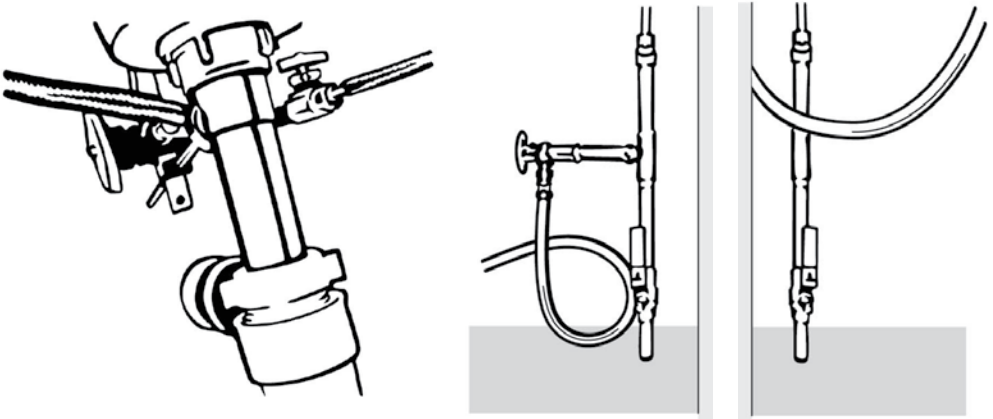

Each toilet has its own shut-off valve. If your shower has a shut-off valve, it may be hidden in the wall behind the shower. Sometimes there's access to the shower's plumbing through an adjacent closet, but not always.

Your washing machine also has its own shut-off valve, on the wall where the hoses are attached. Now, don't you feel more secure knowing that there all these places in your house where you could turn off the water if you needed to?



## Can I Fix a Leaky Faucet Myself?

The answer is “yes . . . possibly.” There are too many kinds of faucets for me to be able to explain them all in detail in a book of this size. But there are two very common types of kitchen and bathroom faucets (ball-type and cartridge) that are reasonably simple in design and are worth the effort of trying to repair before calling for professional help. Unfortunately, it's impossible to know what type of faucet you have without taking it apart, unless you still have the paperwork from when you purchased it.

Here's how I think about it: Best-case, you invest a couple of hours of your time and fix an annoying, water-wasting leak; worst-case, you can't fix the leak, and after a couple of hours you call a plumber. At least you will have had the satisfaction of trying, and you can ask the plumber what you should have done differently, if anything.

I'll tell you the truth about plumbing (it's something your mother would have told you, if she had only known): *Plumbing—especially old plumbing—does not like to be touched!* In several instances, I did everything correctly on a plumbing repair but still ended up with a leak. It goes like this: In order to try repairing a leaky faucet, you have to close the shut-off valves in the cabinet under the sink. You take apart the faucet, replace the suspicious parts, and put the faucet back together. You open the shut-off valve and—hoorah!—the faucet no longer leaks. Then you look under the cabinet and notice that the cold water shut-off valve is leaking. You did absolutely nothing wrong. The shut-off valve is leaking purely

because you touched it. This happens to plumbers all the time. The only difference is that they're prepared to handle it by replacing the shut-off valve if they have to.

I don't want to scare you away from trying to accomplish some minor plumbing repairs. I'm just trying to save you from some of the anguish I have suffered over the years. All my lowest self-esteem days have come on days that I took on plumbing projects without understanding how fickle pipes and valves can be. I want you to be prepared so that, if your plumbing throws you a curveball, you don't blame yourself. Instead you'll say: "Oh, Marie said this might happen! It's not my fault. I'll just call the plumber."

One last thought before we get started trying to fix a leaky faucet: *Never start plumbing projects late on a Sunday afternoon.* Always start them early, and on a day when stores are open and plumbers are available if needed.

## Fixing a Leaky Faucet

Your faucet may be dripping from the spout, or it may be leaking at the base of the handle. Regardless of where the water is showing up, the workings of the faucet are all inside the handle area, and that's where the work needs to be done.

### REPAIRING A CARTRIDGE FAUCET



Tools you will need:

- ✓ Utility knife
- ✓ Philips head screwdriver
- ✓ Water pump pliers
- ✓ Needle-nose pliers

Materials you will need:

- ✓ Paper towels
- ✓ Heat proof grease
- ✓ New cartridge (with washers and springs)

You won't know what kind of cartridge you need until you remove the old one. You should plan on taking a trip to the hardware store once you have disassembled the old faucet.

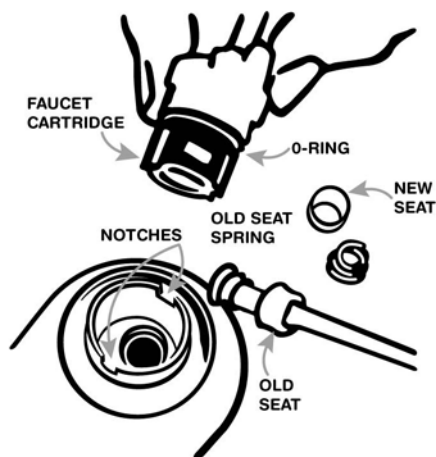

### Step One: Take the Faucet Apart

**1. CLOSE BOTH SHUT-OFF VALVES** (hot and cold) underneath the sink by turning them all the way to the right (clockwise). If you're not able to close one or both valves, you can close the main water valve to the house.

**2. CLOSE THE DRAIN**, and then put a towel over the bottom of the sink to catch any parts that fall (because they *will* fall!).

**3. LAY A TOWEL OUT ON** the counter to place the parts of the old faucet on as you remove them.

**4. USE THE BLADE ON A** utility knife to pry off the index cap on top of the faucet. The index cap is the small, round piece of metal or plastic that may say "hot" or "cold." Lay the index cap on the towel.



**5. UNSCREW THE HANDLE** screw that was hidden by the cap. Place it on the towel, next to the index cap.

**6. REMOVE THE FAUCET** handle by lifting it straight up. Place the handle on the towel, next to the handle screw.



**7. REMOVE THE THREADED** retaining ring with a pair of water pump pliers. There is usually an area near the top where the pliers fit naturally. Unscrew the ring by moving the pliers counter-clockwise. Place the retaining ring on the towel, next to the faucet handle.

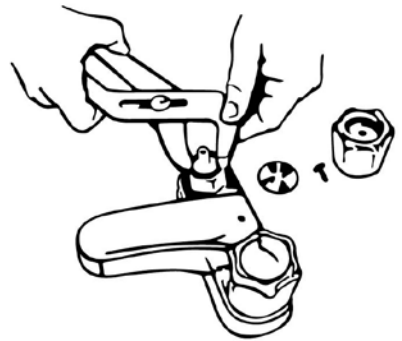

**8. USE YOUR HANDS OR A PAIR** of pliers to remove the cartridge by lifting it up and out. Set it on the towel, next to the retaining ring.

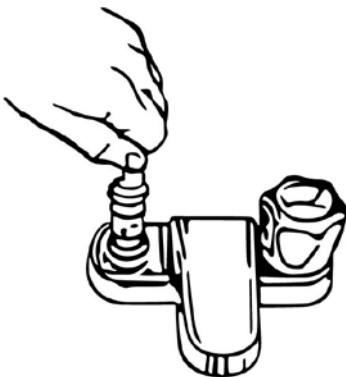

**9. LOOK DOWN INTO THE OPENING** you have created in the faucet; you'll see one or two small black valve seats. Remove them with a pair of needle-nose pliers. Set the valve seats on the towel, next to the cartridge.

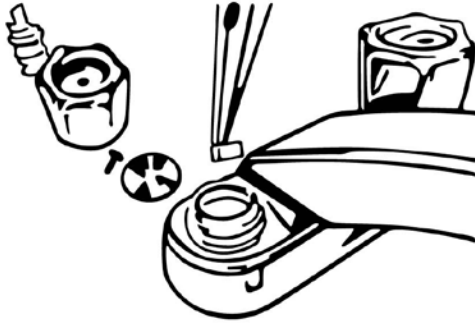

**10. REMOVE THE SMALL SPRINGS** that were covered by the valve seats and place them on the towel, next to the valve seats.

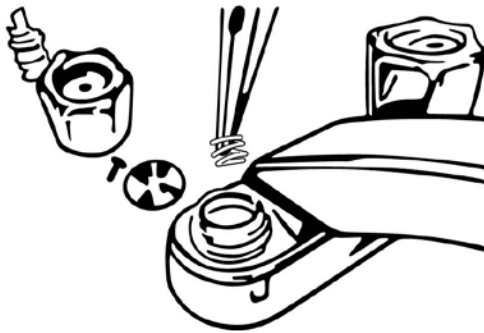

**NOTE:** By laying all the pieces on a towel as you remove them, you have them in the correct order for replacement. When it's time to put the faucet back together, you'll start at the end of your line of parts and work your way back to the beginning of the line. That way, there's no way you can forget a part or put it in at the wrong time.

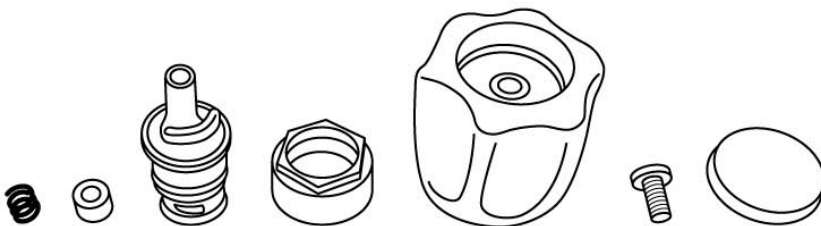

Now it's time for a trip to the hardware store. Place your cartridge, little black valve seats, and springs in a container and take them with you. When you get to the store, ask for a replacement cartridge that matches yours and a new set of valve seats and springs. This is also a great time to pick up some heat proof grease if you haven't gotten it yet. Once you have everything, it's time to start putting it all back together.

### **Step Two: Put the Faucet Back Together**

- 1. PUT A SMALL AMOUNT OF HEAT** proof grease on your pinky finger or on a cotton swab and rub it inside of the little hole (or holes) from which you removed the valve seats and springs.
- 2. PLACE THE NEW SPRING INTO** its hole, making sure that the biggest end of the spring is in the bottom of the hole.
- 3. SET THE NEW VALVE SEAT** over the spring. You may need to use the needle-nose pliers to do this.
- 4. SPREAD SOME HEAT PROOF** grease around the outside of the new cartridge and set it in the opening. In order to make sure the cartridge is set all the way into the opening, you'll have to fit the little tab on the cartridge into a corresponding slot on the metal surrounding the cartridge.

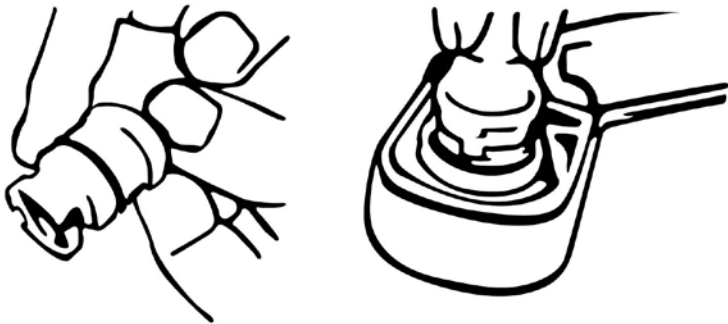

- 5. PLACE THE RETAINING RING** over the cartridge and screw it back into place with the water pump pliers.



**6. SET THE FAUCET HANDLE** back into place.

**7. REPLACE THE SCREW** in the top of the faucet handle.



**8. POP THE INDEX CAP** back into its place.



**9. THE TOWEL ON THE COUNTER** should now be empty: You have replaced the cartridge and washer with new ones, and everything else went back where it belonged.

**10. OPEN THE SHUT-OFF VALVES** by turning them counter-clockwise (or, if you turned off the main water valve for this, go turn it back on).

**11. OPEN YOUR FAUCET;** the leak should be gone. Congratulations!

## REPAIRING A BALL-TYPE FAUCET



Tools you will need:

- ✓ Utility knife
- ✓ Philips head screwdriver
- ✓ Water pump pliers
- ✓ Needle-nose pliers

Materials you will need:

- ✓ Paper towels
- ✓ Heat proof grease
- ✓ Masking tape
- ✓ Faucet ball (with new valve seats and springs)

This kind of faucet is called a ball-type faucet because the part that controls the flow of water is shaped like a ball. The process to replace the ball and fix the leak is almost identical to the process outlined for a cartridge type faucet, but some of the parts are slightly different.

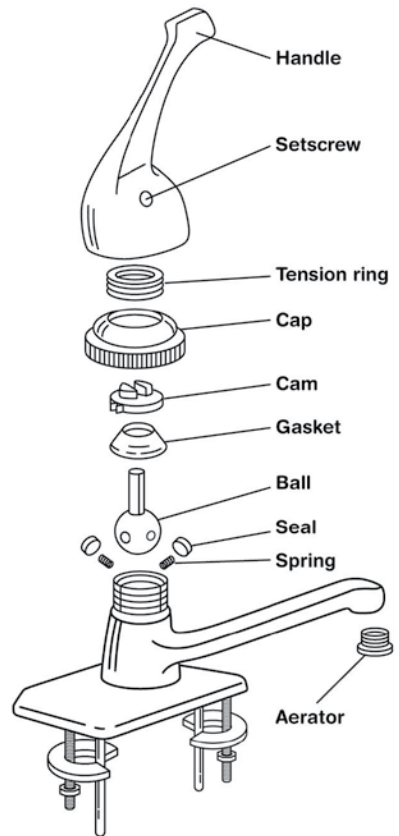

### Step One:

#### Take the Faucet Apart

**1. CLOSE BOTH SHUT-OFF VALVES** (hot and cold) underneath the sink by turning them all the way to the right (clockwise). If you're not able to close one or both valves, you can close the main water valve to the house.

**2. CLOSE THE DRAIN** and put a towel over the bottom of the sink to catch any parts that might fall.

**3. LAY A TOWEL OUT** on the counter to place the parts of the old faucet on as you remove them.

**4. LIFT UP THE FAUCET HANDLE** and look on the underside of its base for an opening. Sometimes the opening is covered by a small plastic disc that has the faucet name on it, or a red/blue symbol denoting hot/cold. Pry this piece off with a utility blade and set it on your towel.

**5. YOU'LL FIND A SCREW INSIDE** the opening. It may be a regular Philips head screw, but more likely it's a set screw, for which you will need the appropriate-size Allen wrench. It may take a couple attempts to match the wrench with the screw; when you do, loosen the screw by turning it to the left (counter-clockwise). If it is a set screw, you don't have to remove it completely, just loosen it until you can lift the handle off. Set the handle and screw on the towel, next to the little plastic thing you removed first.

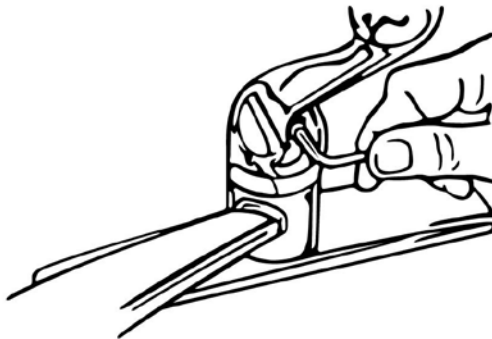

**6. USE A LARGE PAIR OF WATER PUMP** pliers to remove the faucet cap by unscrewing it. You may want to place a little masking tape on the teeth of the pliers to protect the finish on your faucet cap.

**7. SET THE FAUCET CAP** on the towel, next to the handle.

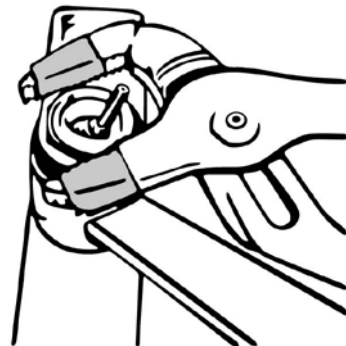



**8. LOOSEN THE FAUCET CAM** with the same pliers and remove it. Set it on the towel, next to the faucet cap.

**9. REMOVE THE CAM** washer and set it next to the faucet cam.

**10. REMOVE THE BALL** and set it next to the cam washer.

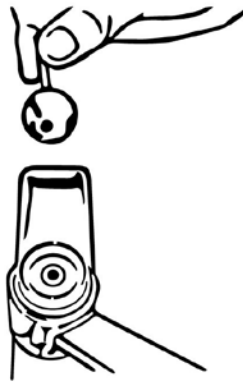

**11. LOOK UNDER WHERE THE BALL** was and remove the two black valve seats and the springs underneath them. Set the valve seats and springs on the towel, next to the ball.

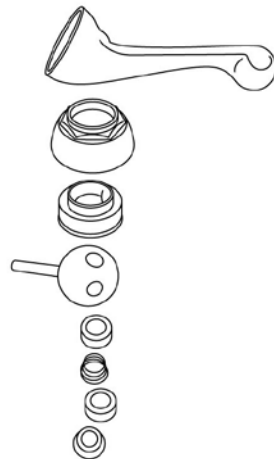
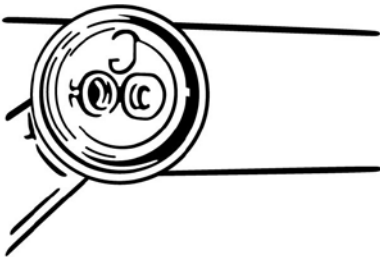

Now you're ready for your trip to the hardware store. Take your ball and valve seats with you and ask the helpful hardware person for a replacement, along with a tube of heat proof grease.

In order to put the faucet back together correctly, you're going to start at the end of the line of parts lying on the towel and work backward, putting them back in place one at a time.

### **Step Two: Put the Faucet Back Together**

**1. PUT A SMALL AMOUNT OF HEAT** proof grease on your pinky finger or on a cotton swab and rub it inside of the little holes from which you removed the valve seats and springs.

**2. PLACE THE NEW SPRINGS INTO** their holes, making sure that the biggest end of each spring is in the bottom of the hole.

**3. SET THE NEW VALVE SEATS** over the springs. You may need to use the needle-nose pliers to do this.

**4. SPREAD SOME HEAT PROOF GREASE** around the outside of the new ball, and set it in the opening. The ball may have a little metal tab on it that corresponds to a small opening into which it must fit. Play around with it until the ball feels like it settles into place.

**5. PLACE THE NEW CAM** washer over the ball.

**6. PLACE THE CAM OVER** the cam washer. There should be a little metal tab on one side of the cam that fits into a corresponding notch on the faucet body. Press the cam into place, with the tab in the notch.

**7. SET THE CAP BACK IN PLACE** and tighten it with a pair of water pump pliers.

**8. SET THE HANDLE BACK** in place and tighten the screw holding it in place.

**9. REPLACE THE LITTLE** plastic tab over the screw (if there was one).

**10. OPEN THE SHUT-OFF** valve by turning them counter-clockwise (or, if you turned off the main water valve for this, go turn it back on).

**11. OPEN THE FAUCET** and see if your leak is gone. If it is, congratulations!

## **General Thoughts on Faucets and Faucet Repairs**

Your faucets may not look like either type I have described here, or they may be the same kind but not have all the parts listed, or they may have more parts than I mentioned. You're not going to know exactly what you have until you open it up. There are many resources available to you in addition to this book: There are entire books on plumbing, which cover a wider range of faucets and faucet issues; if you know what kind of faucet you have, the company might have a website with repair information available; and, if all else fails, you can always do an internet search. Just type in "How to fix a leaky faucet?" and be prepared to wade through the responses you will get.

Because plumbing presents unique challenges, it is that much more rewarding when you solve a problem. If you're someone with a lot of patience who likes to work through issues and who can handle possible setbacks, you may really enjoy working on the minor plumbing issues in your home. If you're someone with less patience and/or someone who doesn't like uncertainty, risk, and solving problems, then plumbing may not be something you choose to take on. That is completely okay.

Even though I can do plumbing, at this point in my life I often call a plumber to do the nastier jobs that I just don't want to mess with. It's important to know your strengths and weaknesses, and choose your projects accordingly.

## **Getting to Know (and Fix) Your Toilet**

For something that we have spent countless hours of our lives on top of, it's remarkable how little most of us know about how a toilet works and how to fix its minor problems. Like many things in our lives, we really don't notice our toilet until it stops working. Most residential toilets are gravity feed toilets, which means that it's the force of the water dropping from the tank into the bowl that flushes

away the waste. When the toilet handle is pressed down, it lifts up the trip lever, which lifts up the flapper ball. The flapper ball covers a large opening from the tank into the bowl; when it lifts, it allows water to flow from the tank into the bowl.

When your toilet is working properly, this entire process is invisible to you. However, three minor (but annoying) problems often arise: the handle can break or get loose, the water level can rise too high, and the flapper ball can wear out. Each of these problems is relatively easy to fix and only one requires shutting off the water. But before we get into all that, let's start by getting to know your toilet.

All the interesting things that can go wrong with your toilet that don't involve a foreign object getting flushed take place in or on the toilet tank.

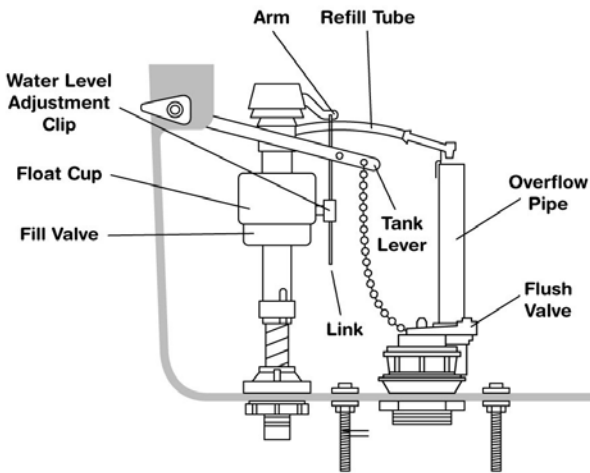

Water enters most toilet tanks through a small pipe located on the lower left-hand side of the toilet tank. The bottom of this pipe is attached to the shut-off valve, which is connected to the cold water pipe (which comes out of the wall or up through the floor near the toilet). It's important to know where this shut-off valve is in case of an emergency (like an overflowing toilet), and for some repairs.

The top of the water pipe or hose connects to the bottom of toilet tank and lets water enter the tank through the ballcock. (Yes, that is what it's called. I could never make up a name that funny.) Older toilets and some current ones have a float ball attached to the

ballcock. In many modern toilets the two are combined; these have a float cup ballcock (try saying that three times, fast) to control the water level in the toilet tank.

Now that we know what the parts in the toilet tank are and what they do, let's fix those three simple problems I mentioned before, starting with the toilet handle:

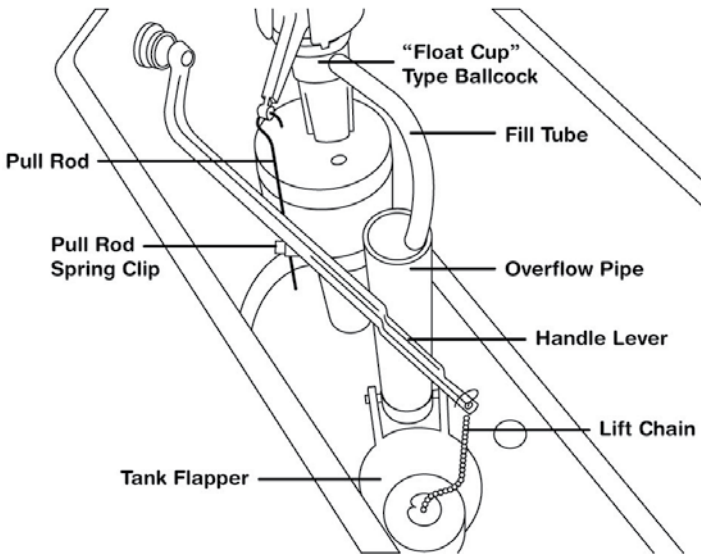

## TIGHTENING OR REPLACING THE TOILET HANDLE

Tools you will need:

- ✓ Water pump pliers

Materials you will (maybe) need:

- ✓ A new handle (with trip lever attached)



**IMPORTANT SHOPPING NOTE:** Before you go to buy your new handle, take note of where exactly it is located on the toilet. It may be on the right or left side, or it may be on the front of the toilet. If you don't know where it is, you can't buy the correct replacement, which is very frustrating.

1. **REMOVE THE LID** from the toilet tank and set it aside.
2. **START BY TIGHTENING** the connecting nut that holds the toilet handle in place on the inside of the toilet tank.



**IMPORTANT NOTE:** The connecting nut is reverse threaded! That means that it twists in the opposite direction from other nuts: You turn it clockwise to loosen it, and counter-clockwise to tighten it. My mother taught me this one!

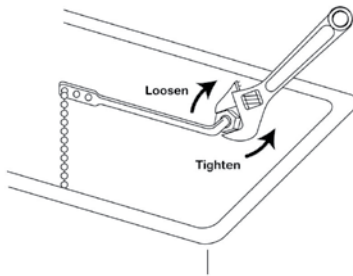

3. **IF TIGHTENING THE CONNECTING** nut solves your handle problem, you're done; if it doesn't, then you need to buy a new handle. The best thing to do is remove the old one and take it with you to the hardware store. To remove the handle, start by completely loosening the connecting nut.

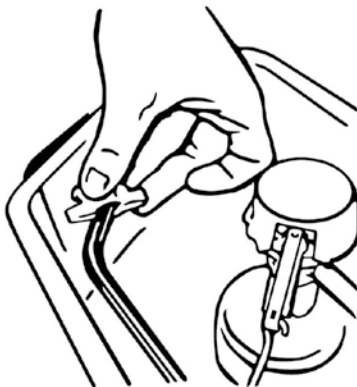

**4. UNHOOK THE LIFT CHAIN** by removing the hook from its hole in the trip lever, but before you do so, make a note of which hole it was in. You'll want to know that when you put it back later.

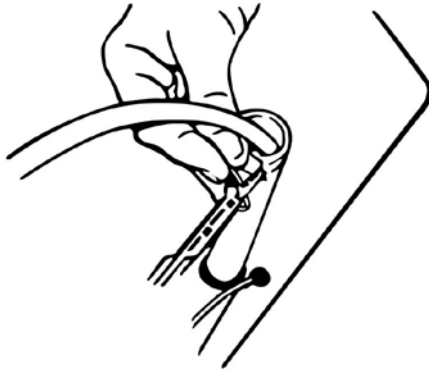

**5. NOW SLIDE THE HANDLE** and trip lever out of the hole in the toilet tank and go buy a replacement.

**6. PUT THE NEW HANDLE** and trip lever through the hole in the tank. Slide the nut onto the trip lever and move it all the way to the end. Start tightening the connecting nut by turning it counter-clockwise with your fingers. Use your pliers to finish tightening the nut.

**7. REATTACH THE LIFT CHAIN** to the trip lever by placing the hook back in the hole where it was originally located.

**8. PLACE THE LID BACK ON** the tank, and you're done. Congratulations! Aren't you glad you didn't hire a plumber to do that?

### **THE MYSTERY OF THE PHANTOM FLUSH**

Have you ever been brushing your teeth and heard the toilet making sounds all by itself? It's usually one of two sounds: Either it sounds like water is running (and, if you can catch it happening, you'll see water filling the bowl), or it sounds like water is filling the tank and shutting off. In order to figure out which phantom is visiting your toilet, you need to do a little detective work.

**1. LIFT THE LID OFF THE TOILET** tank and look inside. The water level in the tank should be about 1 inch below the top of the fill pipe.

If it isn't, and the water is even with the very top of the fill pipe, then it's overflowing, and that's why your toilet is "running." The water level needs to be adjusted.

**2. IF THE WATER LEVEL LOOKS** to be okay, the problem is with the flapper ball—reach into the tank and press down on it. If the water stops "leaking" into the tank, it means that your flapper ball is worn out and needs to be replaced.

## ADJUSTING THE TOILET'S WATER LEVEL

Tools you will need:

- ✓ Your hand

Materials you will need:

- ✓ None

If your toilet has a float ball attached to the ballcock by an arm, you adjust the water level by bending the arm:

**1. GRAB HOLD OF THE ARM** with both hands and bend it slightly downward.

**2. FLUSH THE TOILET AND SEE** if the new water level is lower than the original one. If it isn't, keep bending the arm down and test-flushing the toilet, until the water level is about one inch below the top of the fill pipe.

**3. PUT THE LID BACK** on the toilet tank.

If your toilet has a float cup ballcock the adjustment is slightly different, but the results will be the same:

**1. LOCATE THE SPRING CLIP** on the pull rod and pinch it together with your fingers.

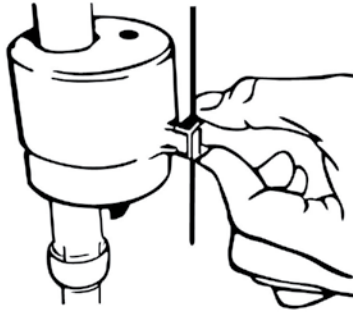

2. **SLIDE IT DOWN** the pull rod a little bit.
3. **FLUSH THE TOILET AND SEE** if the new water level is lower than the original one. If not, repeat keep moving the spring clip down until the water level is about 1 inch below the top of the fill pipe.
4. **PUT THE LID BACK** on the toilet tank.

### REPLACING THE FLAPPER BALL



The previous fixes could be done with the water in the toilet tank, but this one can't, so you have to start by emptying the tank:

1. **CLOSE THE WATER SHUT-OFF** valve (located on the floor or wall near the toilet) by turning it all the way to the right. If it hasn't been closed in a long time, you may need some pliers to help you with this step.
2. **REMOVE THE LID** from the tank.
3. **HOLD THE TOILET HANDLE** down until as much water as possible drains out of the tank and into the bowl.
4. **REACH INTO THE TANK** and unhook the lift chain from the trip lever, taking note of which hole it was connected to.

**NOTE:** If your memory is anything like mine, write this down, because you won't remember later!

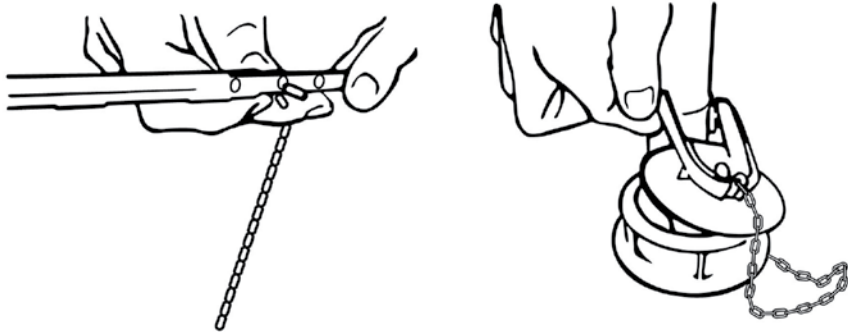

**5. UNHOOK THE FLAPPER BALL** from the ears on the fill pipe by unsnapping it, or by prying it off.

**6. TAKE THE FLAPPER BALL** with you to the hardware store and ask for a replacement.



**SHOPPING NOTE:** There are some universal replacement flapper balls that work on many toilets, but they don't work on all of them. The folks at the hardware store will be able to tell you which replacement flapper ball you need.

**7. THE FLAPPER BALL YOU BUY** may have some extra parts that you don't need. When you get it home, remove or add whatever is necessary to make it look like your old one.

**8. ATTACH THE NEW FLAPPER BALL** to your fill pipe in the same way the old one was attached.

**9. BEFORE ATTACHING THE NEW CHAIN** to the trip lever, you need to make sure it's the same length as the old one. If it's too short the flapper ball can't close completely, and if it's too long it can



get caught under the flapper ball and keep it from closing tightly. Cut the chain to length with a pair of scissors.



**IT HAPPENED TO ME:** I was once in the bathroom at my doctor's office and noticed that the toilet was running, so I did what any self-respecting handywoman would do: I took the lid off the toilet tank and looked inside. The lift chain was too long and was getting stuck under the flapper ball! So, I fixed it.

**10. ONCE THE CHAIN** is the right length, you can reattach it to the correct hole in the trip lever.

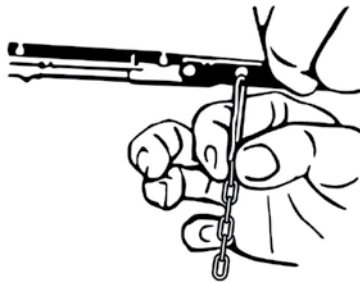

**11. PLACE THE LID BACK** on the toilet tank.

**12. OPEN THE SHUT-OFF VALVE** by turning it all the way to the left, and then back to the right about half a turn.

**13. CONGRATULATIONS**—you did it!

## The Sink Pop-Up Thingy

The technical term for the sink pop-up thingy is the pop-up sink drain stopper. I don't know why all these bathroom terms are tongue twisters, but they are. Feel free to rename them (as I clearly have) for your own purposes! Whatever you call it, that thing at the bottom of your bathroom sink hides a multitude of sins. It is important for you to know how to adjust it when it's not working correctly, and how to remove it for cleaning when it's causing drain problems.



**IT HAPPENED TO ME ONCE:** When both of my bathroom drains were draining very slowly, I assumed that the problem was in the trap underneath the sink. I removed the nut at the bottom of the trap, drained out the water, and stuck my finger and a coat hanger up inside and found no clog. So then I assumed that the problem must be further down the drain system. I poured a rather caustic drain cleaner into my sinks and waited for it to eat away the clog. It didn't.

As a last resort, I removed my pop-up sink drain stopper . . . and I was disgusted by what I saw. It was completely covered in a ball of hair, soap scum, and black slime caused by hair products and all the other things we thoughtlessly send down the drain. I cleaned it off, put it back into the sink, and ran the water, and the "clog" was gone.

A little regular maintenance and an occasional cleaning can prevent the kind of mess I ran into.

## CLEANING YOUR POP-UP SINK DRAIN STOPPER



Tools you may need:

- ✓ Water pump pliers
- ✓ Flashlight
- ✓ Old toothbrush

Materials you may need:

- ✓ Cleaning supplies
- ✓ A strong stomach!

**1. MAKE SURE THE DRAIN STOPPER** is in the full, open position. Try turning it counter-clockwise, hard, and then lifting it out. Some will come out like this, but many won't. If yours does, proceed to step 4. If it doesn't, go on to step 2.

**2. USE YOUR FLASHLIGHT TO** illuminate the area underneath your sink; this area's usually in a vanity, but sometimes it's in plain view.

**3. DIRECTLY BEHIND THE DRAIN** tailpiece—it's not visible from the

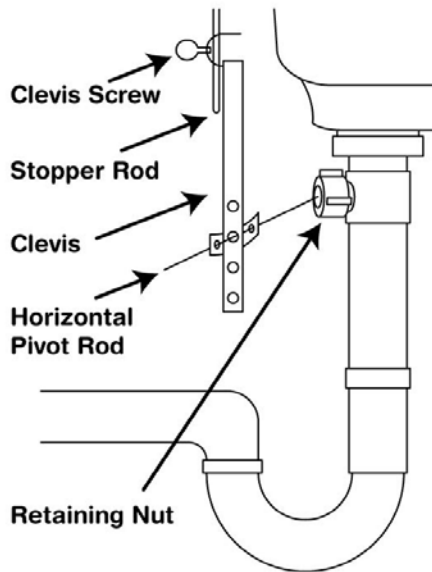

front of the plumbing—is the drain stopper rod, which is connected to the clevis, which is connected to the drain pivot rod. The end of the drain pivot rod that you can't see is what's holding the pop-up drain stopper in the drain.

**4. UNSCREW THE RETAINING NUT** (the nut that's holding the pivot rod in place) with your fingers or the pliers.

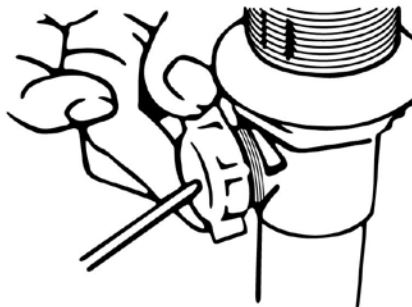

**5. SLOWLY PULL THE PIVOT ROD OUT** of the tailpiece, being careful to catch any little pieces that might fall (I once lost a washer that I didn't know was there during this step).

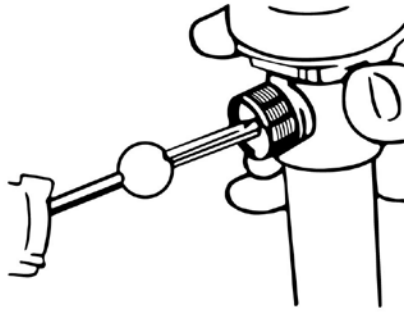

**6. NOW THE POP-UP SINK DRAINER** should easily lift out of the sink for cleaning. While it's out of the drain, take the opportunity to clean the drain. Shine your flashlight down into the drain—you may be surprised at what you see. Use an old toothbrush to scrub the walls of the tailpiece.

**7. ONCE THE SINK STOPPER IS** clean, set it back into the drain.

**8. PUT THE PIVOT ROD BACK IN** place and gently hand-tighten the retaining nut.

**9. TEST TO SEE IF THE SINK STOPPER** is being held in place by the pivot rod by lifting the stopper lever up and down.

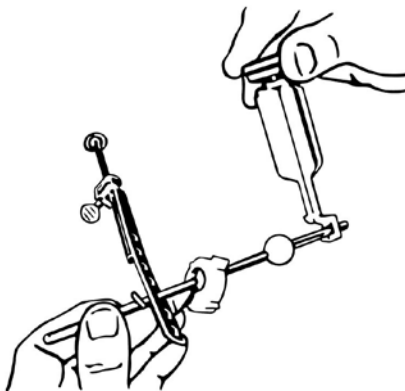

(These are the parts out of the sink, so you can see what is happening inside the tailpiece.)

**10. If it isn't, you'll have to** remove the pivot rod and change the orientation of the sink stopper until it's in the correct position for the pivot rod to "catch" it.

**11. ONCE EVERYTHING IS WORKING** correctly, finish tightening the retaining nut by hand. If you need to use pliers to do this, use them gently. If you over-tighten the retaining nut, the sink stopper will not move up and down easily.



**TIP:** Pour really hot water down your drains once a month. This will help prevent the yucky build-up in the drains and on the sink stopper. Remove the sink stopper once a year for cleaning, whether you think it needs it or not. My mother taught me this one, too.

## FIXING YOUR SINK POP-UP DRAIN STOPPER



If your sink pop-up drain stopper doesn't move up and down anymore, it's probably because the pivot rod has slipped out of its hole in the clevis. What the heck is a clevis? It's the thing that connects the drain stopper rod to the drain pivot rod. There's a little, bent piece of metal called a spring clip that holds the end of the pivot rod onto the clevis. Sometimes the spring clip falls off, preventing the sink stopper from moving up and down, but you can replace it easily:

**1. SLIDE ONE END OF** the spring clip onto the pivot rod.



**2. PUT THE END OF THE PIVOT** rod into a hole on the clevis.

**3. SLIDE THE OTHER END OF** the spring clip onto the end of the pivot rod protruding through the clevis. There should be tension in the spring clip.

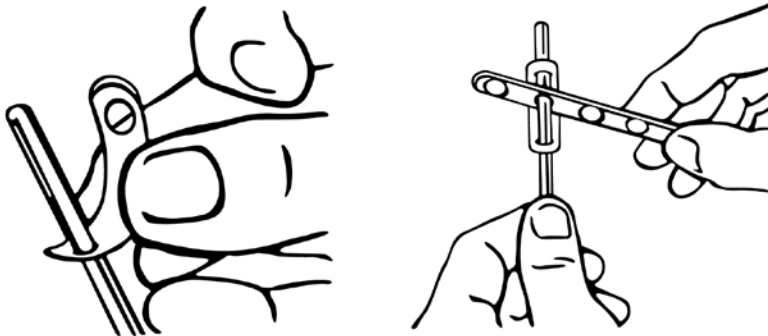

**4. IF THERE'S NO TENSION IN** the spring clip, you need to open it up a little by pulling the ends away from each other; then you can reattach it to the pivot rod.

**5. MOVE THE PIVOT ROD UP** and down. The drain stopper should now move with it. If the drain stopper does not open or close all the way, you need to move the end of the pivot rod to a new hole in the clevis.

**6. I WISH I COULD TELL YOU EXACTLY** which hole you need to use, but I can't. Experiment by moving the pivot rod into a new hole, reattaching the spring, and testing it. Continue trying different holes until the drain stopper opens and closes to your satisfaction.

## Shower Heads

Removing an old shower head and replacing it with a new one is a favorite project of mine because it doesn't involve shut-off valves. Remember what I said at the beginning of this chapter about plumbing not liking to be touched? Well, you don't have to touch any "real" plumbing in order to replace your shower head. You just have to make sure the shower handle is in the "off" position, and

then you're ready to start. However, to be safe, stand to the side when you finish unscrewing the shower head; there's usually some water still in the pipes, and you may get an unexpected shower if you're standing directly in front of the head.

## REPLACING A SHOWER HEAD

Tools you will need:

- ✓ Water-pump pliers

Materials you will need:

- ✓ Masking tape
- ✓ Teflon plumbing tape
- ✓ New shower head

**1. WRAP SOME MASKING TAPE** around the teeth on your pliers to prevent scratching the surface on the shower head.

**2. UNSCREW THE SWIVEL BALL** nut by turning the pliers counter-clockwise.

**3. CLEAN OFF THE THREADS AT THE** end of the shower arm, removing any old tape or debris.

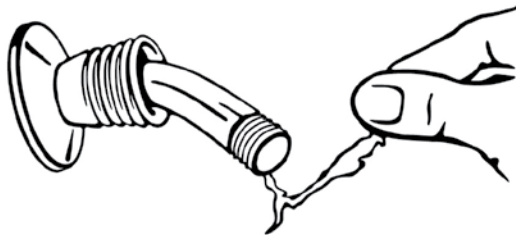
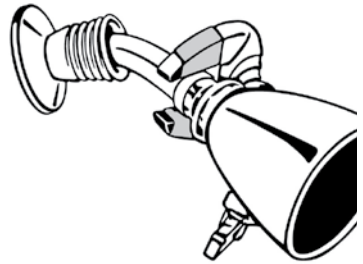

**4. WRAP A PIECE OF TEFLON TAPE** (about 4 inches long) around the threads, clockwise, pulling it tight so that it stretches and grabs. Smooth down the end. This tape helps seal the joint between the threads and the swivel ball nut, preventing leaks.

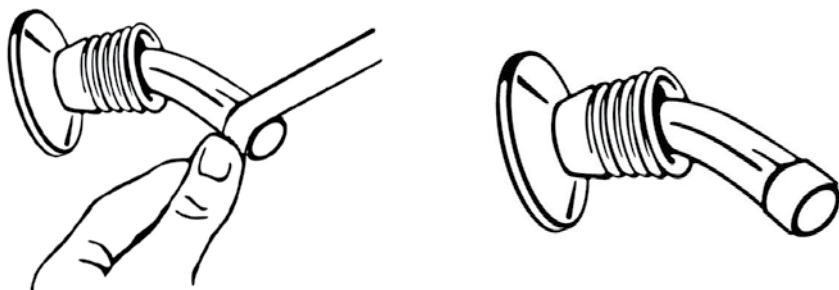

**5. SCREW THE SWIVEL BALL NUT** of the new shower head on to the threads by hand, and then finish tightening it with your pliers.

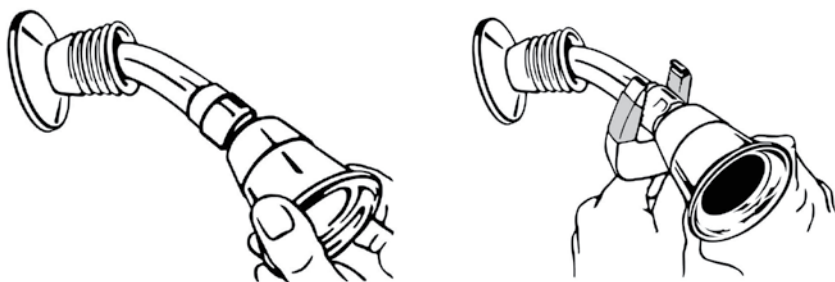

**6. TURN THE WATER ON TO SEE** if you have any leaks; if you do, continue to tighten the nut until the leaking stops.

**7. ENJOY YOUR NEW** shower head.



**TIP:** If you like your old shower head but it doesn't seem to work as well as it used to, try cleaning it before replacing it. First, fill a quart- or gallon-size bag with equal parts vinegar and water. Place the bag over the shower head so that the shower head is fully submerged. Tie the bag in place and leave it there overnight (or longer). The vinegar can dissolve mineral build-up in the shower head that's clogging the holes.

## Cleaning and Replacing Sink Faucet Aerators

Tools you will need:

- ✓ Water pump pliers

Materials you will need:

- ✓ Masking tape
- ✓ Toothbrush

Each of your kitchen and bathroom faucets has an aerator on its tip that reduces water flow and evens out the water pressure. Over time, aerators can get clogged with minerals and tiny rocks. This almost always happens when the main water supply has been shut off for plumbing repairs. When the water is turned back on, debris from the repairs flows to your faucets and gets caught in your aerators. If you have noticed that your water pressure seems reduced or the water is coming out of your faucet unevenly, it's time to remove your aerators and clean or replace them.

### CLEANING YOUR SINK FAUCET AERATOR

**1. CLOSE OR PLUG THE DRAIN** in your sink, lay a towel down in the sink to catch any parts that may fall, and lay another towel down to the side to place the parts you remove on.

**2. WRAP SOME MASKING TAPE** around the teeth on your pliers to avoid scratching your aerator.

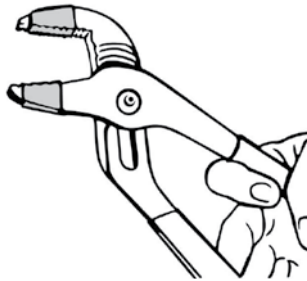

**3. UNSCREW THE AERATOR** with the pliers by turning it counter-clockwise. Once you get it loosened, you'll be able to unscrew it with your fingers.

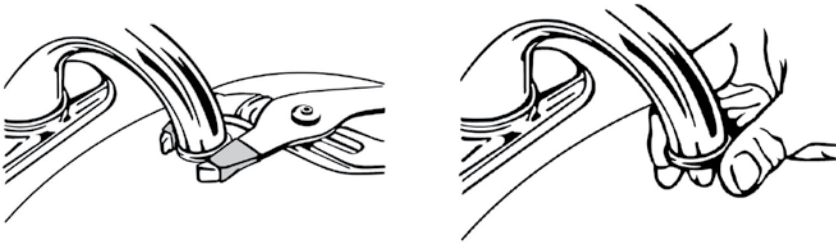

**4. CAREFULLY DISASSEMBLE IT** by laying each part down on the towel you put down to the side, in the order they were removed.



**5. CLEAN EVERYTHING**, especially the screen, with the toothbrush.

**6. REASSEMBLE THE AERATOR** and reattach it to the faucet by turning it clockwise. Tighten it with the pliers

**7. TURN THE WATER BACK ON** and see if cleaning the aerator solved your problems.

**8. IF IT DIDN'T, YOU'LL** need to replace the old aerator with a new one.

### REPLACING YOUR SINK FAUCET AERATOR



**1. AFTER REMOVING THE OLD** sink aerator (see steps 2 and 3 of the last section), take it with you to the hardware store. You need to have it with you, because they come in different styles and sizes. If you have a really fancy faucet, you may need to get a new aerator directly from the manufacturer.

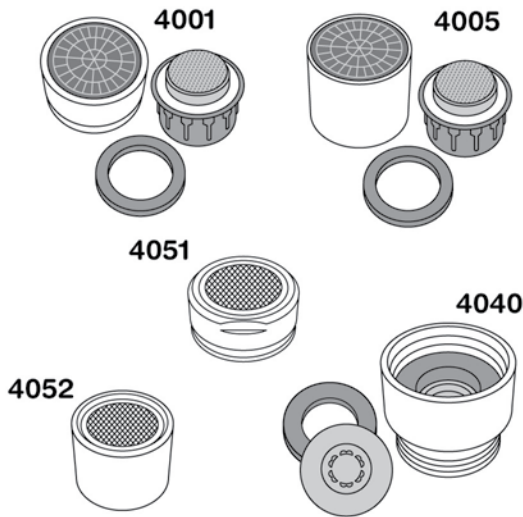

**2. WHEN YOU GET HOME**, screw the new aerator (clockwise) onto your faucet and test for leaks. Tighten it as much as necessary.



**TIP:** Clean your aerators once a year and you'll probably be able to avoid ever having to replace them! Always clean your aerators out after any plumbing has been done in your home that required the water to be shut off.

## Removing and Laying Caulk

One of the simplest but most effective deterrents against future water problems in your bathroom is a bead of caulk. Caulked joints are most commonly found in your shower stall and tub surround. You may also find caulk on the joint where countertops meet the wall, and around the shower handle escutcheon (for a lot more information about caulk, read Chapter 2.)

People usually don't notice the caulked joints in their homes until the joints start to look really gross, or until they notice a leak somewhere and trace it back to a defective caulk joint. There is no reason to disturb your caulked joints as long as they are mold- and

mildew-free and still doing their job well. But, eventually, many caulked joints will need to be removed and replaced with new caulk.

## REMOVING OLD CAULK



Tools you will need:

- ✓ Six-in-one painters tool,
- ✓ Razor blade scraper

Materials you will need:

- ✓ Rubbing alcohol
- ✓ Clean cloth
- ✓ “Caulk-Be-Gone” product (for removing latex caulk, see Shopping Tip in step 1 for details)

As soon as you start trying to remove your old caulk you'll find out if it's silicon or latex. Old silicon caulk remains pliable and somewhat soft, while old latex caulk is very hard, brittle, and difficult to remove.



**1. USE THE POINTY END OF THE** painter's tool to get under an end of the caulk and lift it up a little. If you can grab onto the end with your fingers and start pulling the caulk up, then you have silicon caulk. If the caulk is very hard and almost impossible to dig out, you have latex caulk.



**SHOPPING TIP:** If you have latex caulk, there's a product you can buy that really helps with the removal process. It's called "Caulk-Be-Gone," and it's made by DAP. You can usually find it in the caulk aisle at major home centers; I've never had luck finding it at my hardware store. Buy a tube, cut the tip off with scissors or a utility knife, and spread a bead of it onto your old latex caulk. It looks like green toothpaste. Be liberal with it, and then let it sit for at least two hours. Then proceed to step 2.

**2. DIG THE CAULK OUT OF** the joint, using the painter's tool or whatever other tool you find that works.

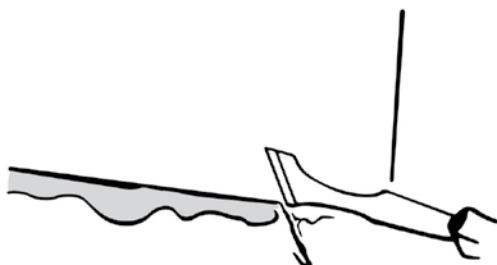

**3. USE THE RAZOR BLADE** scraper to scrape up any pieces or residue left behind.

**4. THOROUGHLY CLEAN THE AREA** with soap and a scrubber of some sort. Wipe the area dry, and then clean it with a clean cloth and some rubbing alcohol. *The new bead of caulk will not adhere well unless the area is really clean.*

### LAYING A NEW BEAD OF CAULK



Tools you will need:

- ✓ Caulking gun
- ✓ Utility knife

Materials you will need:

- ✓ Tube of caulk
- ✓ Paper towels or rags

Laying down caulk is a somewhat difficult job that looks easy when you see someone else that has lots of experience doing it. I am living proof that—with enough practice—anyone can become quite proficient with a caulking gun.

**1. START BY CUTTING THE TIP** off your tube of caulk with a new blade in your utility knife. Make the cut at an angle, starting about 1/8 of an inch from the tip and cutting back, toward the tip. Do not cut straight across the tip.

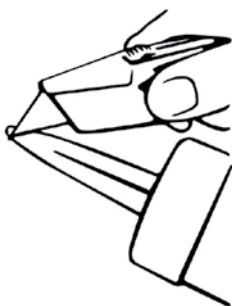

(correct angle for cut)

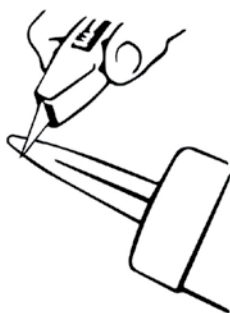

(incorrect angle to cut)



**IT HAPPENED TO ME ONCE:** A mistake I once made happened while I was tiling the walls around the tub in a bathroom my clients were remodeling. There had been a leak in the old tub, so my client's husband had installed the new tub with new plumbing. There were still holes in the floor, under the tub, which we were waiting to close until the bathroom project was complete and we were sure the leak was fixed. I backed up to admire my tile job, and I knocked over a bucket containing about three gallons of water! Fortunately, since tiling is a very wet job, I had a lot of towels on hand. Some water did run under the tub, but it continued down through the open holes in the ceiling, so no new damage was created.

**2. PUNCTURE THE SEAL AT THE BASE** of the nipple, using a long nail or the pointy part of your caulking gun.

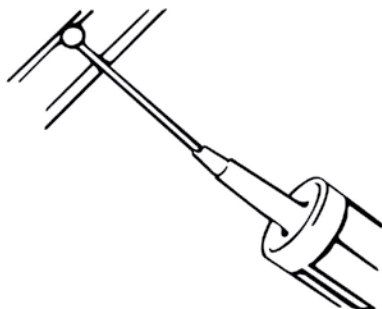

**3. PLACE THE TUBE OF CAULK INTO** the gun and squeeze the trigger gently, just until a small amount of caulk comes out the tip.

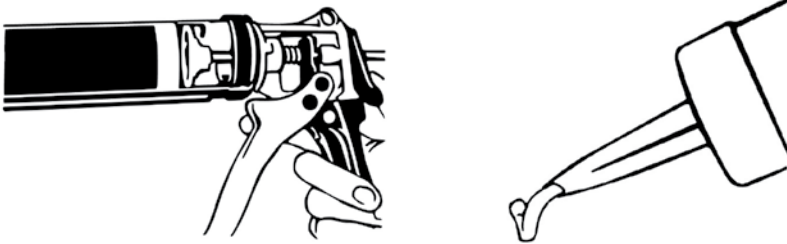

**4. DISENGAGE THE TRIGGER,** and then wipe the tip clean with paper towel or rags. I use paper towels; caulk doesn't wash out of fabric.

**IMPORTANT NOTE:** I strongly recommend that you take some time to practice using the caulking gun before you try laying your actual beads of caulk for this project. Even if you have to buy an additional tube of caulk just for practicing, it will be worth it.



**IT HAPPENED TO ME ONCE:** I was once hired by a woman to help her with a list of projects, including teaching her how to caulk her kitchen countertop where it met the backsplash. I demonstrated how it was done, explaining my technique as I went along, and then I handed her the caulking gun and she stepped up to the countertop. She proceeded to lay down a perfect bead of caulk. My jaw dropped—no one does that well the first time! She looked at the expression on my face and said, “I frost cakes.” That explained it.

**5. SET THE TIP OF THE TUBE OF CAULK** in a corner, or at the end of the area you are caulking, and gently squeeze the trigger. Start pulling the caulking gun toward you and move slowly along the joint.

Your goal is a thin, even bead of caulk, with no gaps or lumps. The rule of thumb with caulk is “less is more.” You can always go back and add some if necessary. It is much harder to remove excess!

**6. WHEN YOU GET TO AN END** point, disengage the trigger and set the tube down on a rag or paper towel (the tube will often leak caulk even after you have disengaged the trigger).

**7. NOW IT'S TIME TO SMOOTH** out the bead of caulk. You want a smooth, concave bead, with no gaps. There are numerous tools and gadgets on the market for smoothing out caulk, and I have tried several—none have measured up to my tried and true trusty tool, my index finger. I wet the tip of my finger (yes, I stick it in my mouth) and gently pull it along the bead of caulk, occasionally lifting it to wipe any excess caulk onto a rag.

**8. IF, AFTER SMOOTHING OUT** the caulk, you notice an area with a gap in the caulk, apply a small amount to that area and smooth it out.

**9. REPEAT THESE STEPS UNTIL** you have covered all the areas needing caulk.

**10. CONGRATULATIONS!** You have just completed a rather difficult job. Rest assured that next time it will be easier, and you will get better with practice.

**IMPORTANT NOTE:** Tubs and showers should not be used for 24 hours after applying new caulk.

## Grout

If you have tile on the walls of your tub or shower, it's important that the grout between those tiles is in good condition. While grout does have an aesthetic purpose, its real reason for existing is to seal the space between the tiles, preventing water from getting behind them. I have lost count of all the times I have been called to replace tile and the wall behind it because water had gotten behind the tile and done major damage. Prevention through ongoing maintenance is much easier than major repairs will be.

Next time you're cleaning the tile in your bath or shower, look closely at the grout lines. Pay special attention to the bottom 4 feet of tile and grout. You're looking for any areas where the grout

appears to have fallen out or is loose. Grout should be rock hard, and you shouldn't be able to move it. If you find any areas that look suspicious, mark them with a pencil or a piece of tape.

## REPAIRING GROUT



Tools you will need:

- ✓ Grout removal tool (or utility knife with new blades)
- ✓ Putty knife
- ✓ Rubber spatula
- ✓ Vacuum cleaner

Materials you will need:

- ✓ Grout
- ✓ Container for mixing
- ✓ Whisk or fork
- ✓ Grout removal sponge (or new kitchen sponge)



**TIP:** You can purchase a grout removal tool if you like. I own two, but I usually use my utility knife, and it does a better job for me. The secret is to change the blade often; it gets dull very quickly doing this kind of dirty work!

**1. USE YOUR UTILITY KNIFE** (or grout removal tool) to scrape away all the loose grout that you can find. Be very careful. I keep both hands on the knife to reduce the chances of hurting myself. Anytime you're exerting force on a knife containing a sharp blade, you want to be constantly aware of where your fingers are in relation to the blade.

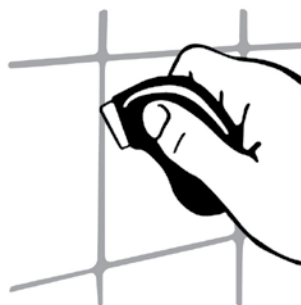

**2. CONTINUE SCRAPING UNTIL** you have removed all the loose or damaged grout.

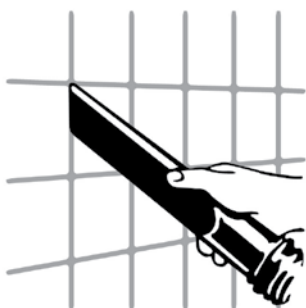

**3. USE THE VACUUM CLEANER** over each grout line to clean the area and remove anything left behind by your knife.

**4. WIPE THE SURFACE** clean with a damp sponge.



**SHOPPING TIP:** If your grout is white or off-white, you may be able to purchase small tubs of pre-mixed grout. Purchase a grout color that most closely matches your grout, but don't worry if it is not perfect. It's very difficult to match existing grout colors. Also, most shower and bath tiles use unsanded grout because the grout lines are less than 1/8 of an inch wide. If your grout lines are wider than that, you will need sanded grout.

**5. IF YOU WERE ABLE TO PURCHASE** pre-mixed grout, move on to step 6. If not, you'll need to mix some grout. The instructions on the package tell you how much water to use if you're mixing the entire package of grout. It's highly unlikely that you will need that much grout, however. I suggest mixing small amounts at a time; you can always mix another batch if you run out. Start by putting a 1/2-cup of clean, cool water in a clean plastic container. Slowly add small amounts of grout and stir it with a whisk, a fork, or your spatula. Continue adding grout and stirring until the mixture is the texture of a thick pudding. It should not be wet and runny; nor should it be so stiff that you can hardly move it. Let it set for a few minutes.

**6. TAKE A SMALL AMOUNT OF** grout on your spatula or putty knife and press it into the grout lines that you cleaned out. Press hard to ensure that the grout really fills them up. Don't worry about it if you get some new grout onto the existing grout; you'll wipe it off later.

**7. LET THE GROUT SIT** for about 10 minutes.

**8. USING A DAMP (NOT WET)** sponge, gently rub over the areas where you put the new grout. Use the sponge to shape the grout so it's concave, not convex. Wipe off any excess grout that's lying on top of the tile; you want the grout to be *between* the pieces of tile, not on top of them! Be careful not to wipe the grout out of the lines. You're trying to match the new grout lines to the existing grout lines.

**9. STOP WIPING ONCE ALL THE GROUT** lines look good and no large amounts of excess grout remain on the tile surfaces. *Do not* try to get the tile perfectly clean at this point. It will have a haze on it (created by grout residue) that you will remove later, when the grout is drier.

**10. LET THE GROUT SIT** for at least a couple of hours.

**11. WIPE THE ENTIRE SURFACE** of the tile with a soft, dry, clean cloth. This should remove any remaining grout haze.

**12. DO NOT USE THE TUB** or shower for at least 24 hours.

**13. CONGRATULATIONS!** You have completed a less-than-fun job that's extremely important to maintaining the integrity of your house.

## **Final Thoughts on Water-Related Plumbing Projects**

If you just completed most or all of the projects in this chapter, you should be very proud of yourself. After electrical projects, women seem to have the most trepidation about taking on plumbing projects . . . which is why it's so satisfying to sit on your toilet that no longer leaks, take a shower under your new shower head, and wash your hands under your clean aerator or new faucet. Not only will your bathroom look and feel better now, you can rest assured that you are avoiding expensive water-related repairs down the road.